

A (Ø-boring): 100,60mm

B (Ø-pen): 32mm

C (centerafstand) : 59.7mm

D (totale lengte) : 101,2mm

E (tussenmaat drijfstang) : 40mm

F (penlengte) : 84mm

G (Ø-compressiekamer) : 47mm

H (diepte compressiekamer): 13.5mm

Zuiger met zuigerringen : JA

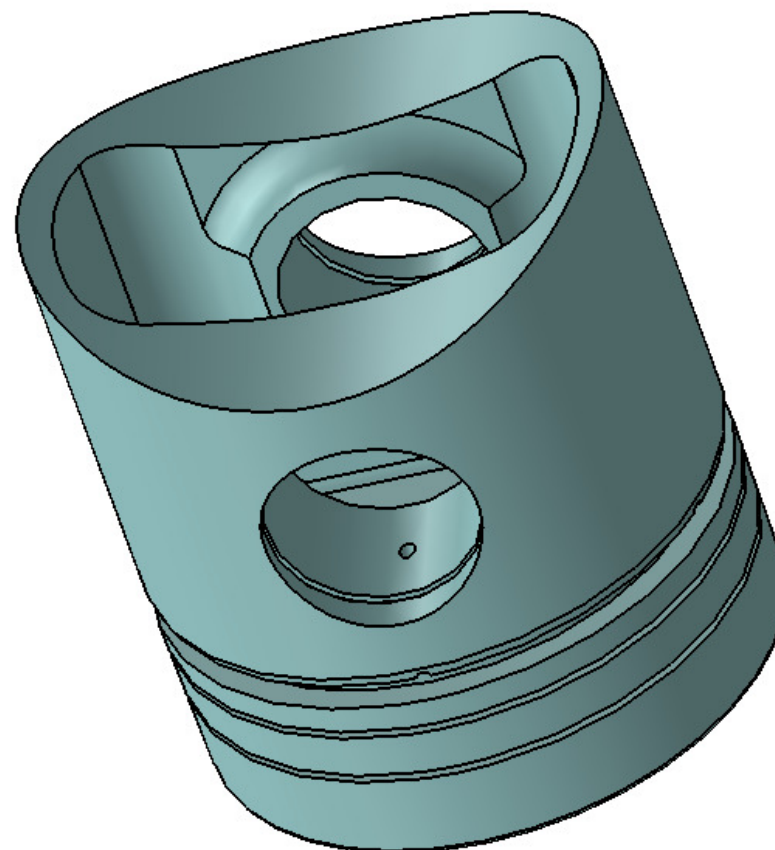
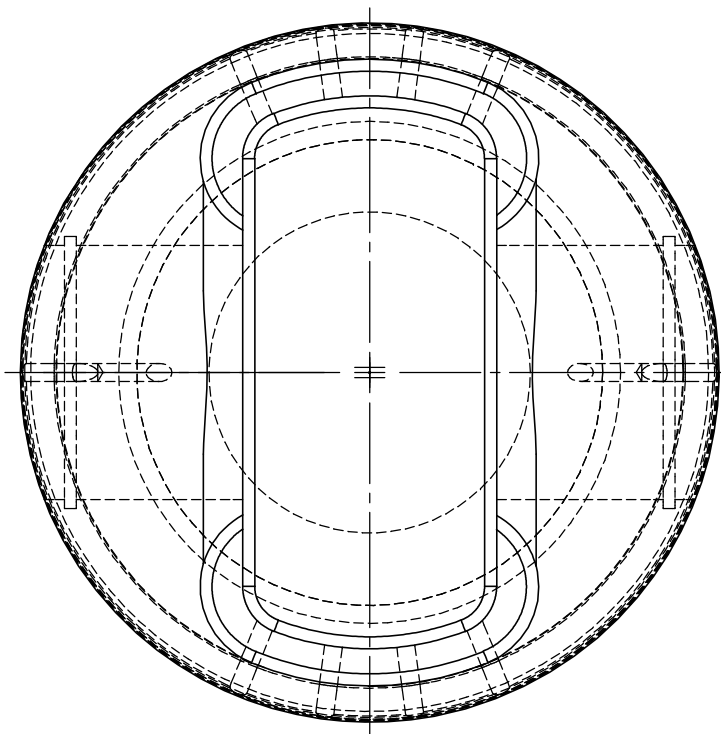

Schaal: 0.8:1	EURO-PROJECTIE		MATERIAAL: 7075-O (SS)
www.omnipull.com		Copyright © omnipull. All rights reserved	AANTAL:
		GETEKEND	Van Egroo F.
		DATUM	24/11/2017
		KLANT	
		GEWICHT	1.73 kg
		PLANNR.	1901134